

Melody mVerse Baffles

Top Clamp1 - Ceiling Installation

APPLICATION:

For ceiling mounting Melody mVerse Baffles using a Top Clamp1.

TOOLS NEEDED:

Drill, 5/16" Spade Drill Bit, (1) Slotted Screwdriver

MOUNTING HARDWARE:



Top Clamp1
(available in white or silver)



Threaded Through
Bolt 1(TTB)

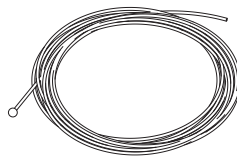

10' Cable
with Swage

INSTALLATION INSTRUCTIONS:

1. Each mVerse Baffle requires two (2) Top Clamp1s. Units over 72" require a third Top Clamp1 in the center. Measure 12" from the top corner and mark. Measure and locate center of baffle if unit is over 72"
2. Align one edge or center of the Top Clamp1 on the 12" mark then locate the holes on the side of the Top Clamp1 and mark the mVerse Baffles through the holes. Mark location of center Top Clamp1 if required.
3. Remove the Top Clamp1 and drill one (1) 5/16" hole. Repeat on the opposite top corner and for all remaining mVerse Baffles.
4. Insert the cable up through the top hole in each Top Clamp1. Pull cable through Top Clamp1 until the swage sits snug inside Top Clamp1.

Step 1

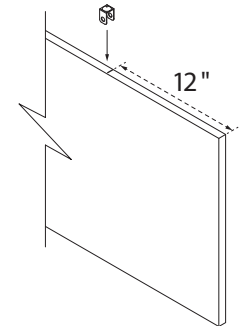

Step 2

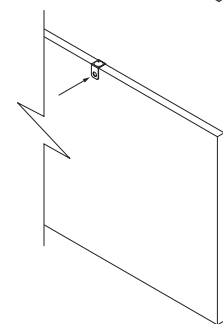

Step 3

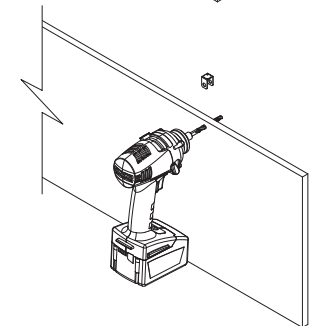

Step 4

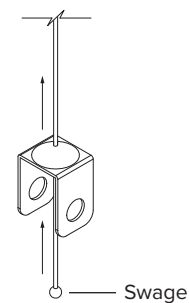

Melody

Melody mVerse Baffles

Top Clamp1 - Ceiling Installation

- Slide mTop Clamp onto mVerse Baffles, aligning Top Clamp1 hole with 5/16" pre-drilled holes in baffles. Attach using the Threaded Through Bolts. **Ensure all mVerse Baffles' fronts are facing the same direction.** Hand tighten with slotted screwdriver. Repeat for all.

The mVerse Baffle is now ready to hang. Use appropriate fasteners and hardware to install the baffles from the structure. All cables from mVerse baffle must be hung plumb and all mounting points in-line, failure to do so can cause baffle to curve or bend. Remove all stickers before hanging.

HANDLING AND STORAGE

Melody panels must be stored indoors in a dry, climate controlled environment at all times. Exposure to moisture, excessive heat or humidity can cause panels to warp and/or stain.

Panels should be stored in a flat, fully supported, horizontal position and NOT on edge. It is recommended that 2 people carry each panel. Panel should be carried on edge, being careful not to bend panel at any time. Clean white gloves are also recommended when handling Melody panels.

Step 5

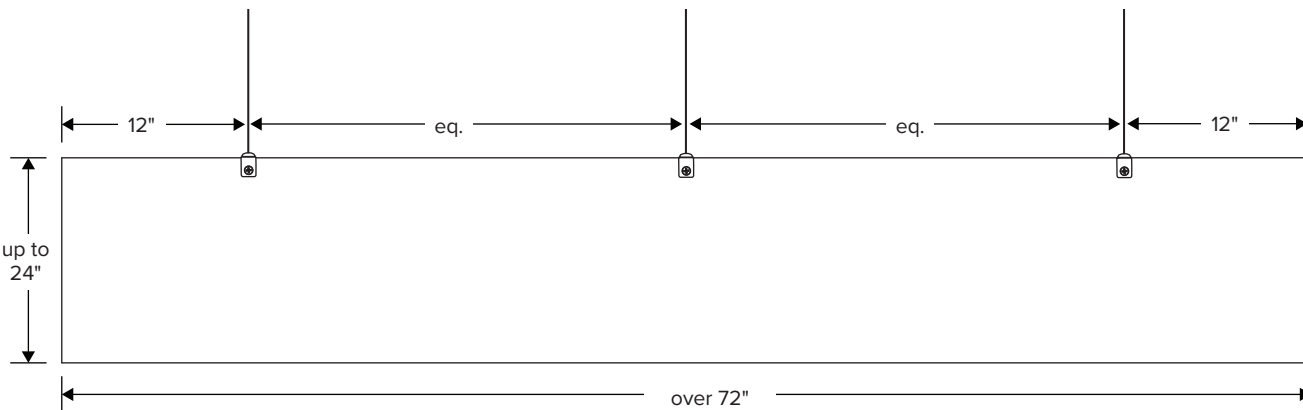
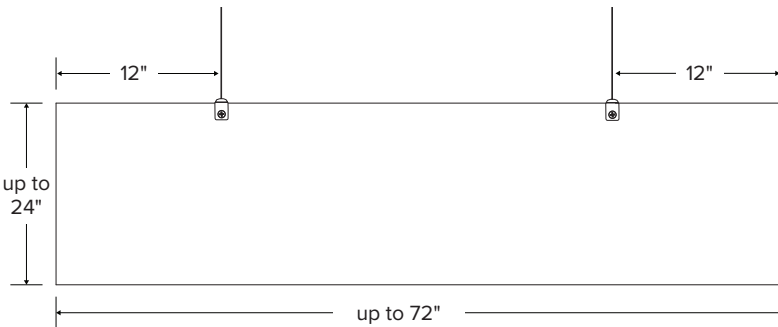
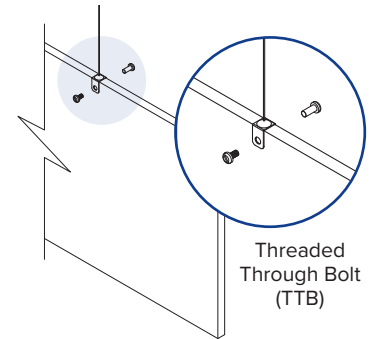

Melody