

aCapella SCORES - GamiLayer, Flute, and SlatWorks - Wall Panels

AM-Clip with Adhesive - Wall Installation



APPLICATION:

For wall mounting aCapella Scores, Scores-GamiLayers, Scores-Flute and SlatWorks with adhesive and AM-Clips on painted or primed drywall.

TOOLS NEEDED:

Heavy Bodied Water-Based Adhesive, Utility Knife, Straight Edge, Drill

MOUNTING HARDWARE:

AM-Clip

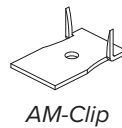

INSTALLATION INSTRUCTIONS:

1. Determine panel placement on the wall. Install two (2) AM-Clips for each panel with fasteners (by others) to the wall. AM Clips should be spaced 4" down from the top of the panel and 4" in from the edge. AM-Clips are designed to hold panel in place while the adhesive dries. **See Figure 1.**

Caution: AM-Clip points are sharp.

2. Lay the panel face down on a flat, clean surface.
Note: Back side of each panel should be clearly labeled. Follow the directional label on the back of the panel for installation orientation. All panels should be installed with the same orientation.
3. Apply a 1/4" bead of heavy bodied water-based adhesive to the back of each panel in a zig zag pattern as shown below. Cover the entire wall panel, keeping adhesive 1/2" away from each edge. **See Figure 2.**
4. Being careful not to touch the adhesive, lift the panel, in place. Apply panel to the wall, pressing firmly on the front face of the panel to engage the adhesive and AM-Clips.
5. To ensure the panels are evenly secured, apply pressure with hands moving them from center to outer edge of each wall panel.
6. Use a straight edge and utility knife to cut panels to fit around odd angles, lights and other penetrations.

Note: Due to inconsistencies in the aCapella core thickness, some shimming may be required to align the panels edges.

HANDLING AND STORAGE

aCapella panels must be stored indoor in a dry, climate controlled environment at all times. Exposure to moisture, excessive heat or humidity can cause panels to warp and/or stain.

Panels should be stored in a flat, fully supported, horizontal position and NOT on edge. It is recommended that 2 people carry each panel. Panel should be carried on edge, being careful not to bend panel at any time. Clean white gloves are also recommended when handling aCapella panels.

MOUNTING DETAILS:

Figure 1

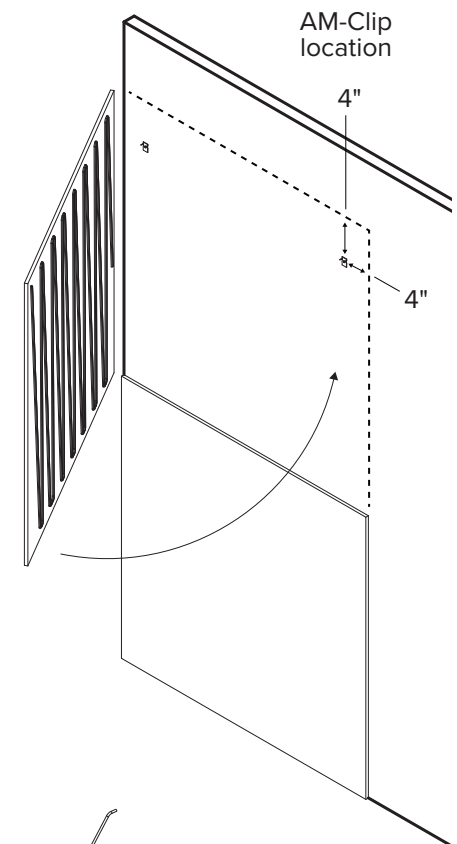
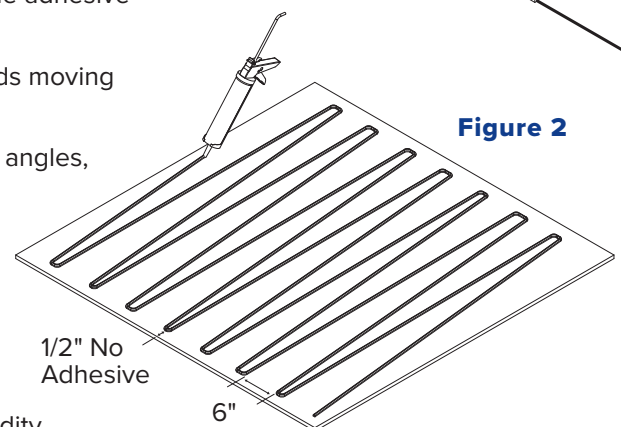

Figure 2



Ribbon Pattern or Zig Zag Pattern with Perimeter Bead on back of panel