

# aCapella SCORES - GamiLayer, Flute - Wall Panels

## AM-Clip with Adhesive - Wall Installation

### APPLICATION:

For wall mounting aCapella Scores, Scores-GamiLayers, and Scores-Flute with adhesive and AM-Clips on painted or primed drywall.

### TOOLS NEEDED:

Heavy Bodied Water-Based Adhesive, Utility Knife, Straight Edge, Drill

### MOUNTING HARDWARE:

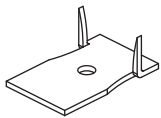

AM-Clip

*(Fasteners to attach AM-Clip to wall by others)*

### INSTALLATION INSTRUCTIONS:

1. Determine Scores panel placement on wall. Install two (2) AM-Clips for each Scores with fasteners (by others) to the wall. AM Clips should be spaced 4" down from the top of the panel and 4" in from the edge. AM-Clips are designed to hold panel in place while the adhesive dries.  
**Caution: AM-Clip points are sharp.**
2. Lay the Score panel face down on a flat, clean surface.  
**Note: Back side of each Score panel should be clearly labeled.**  
**Follow the directional label on the back of the panel for installation orientation. All panels should be installed with the same orientation.**

### MOUNTING DETAILS

#### Step 1

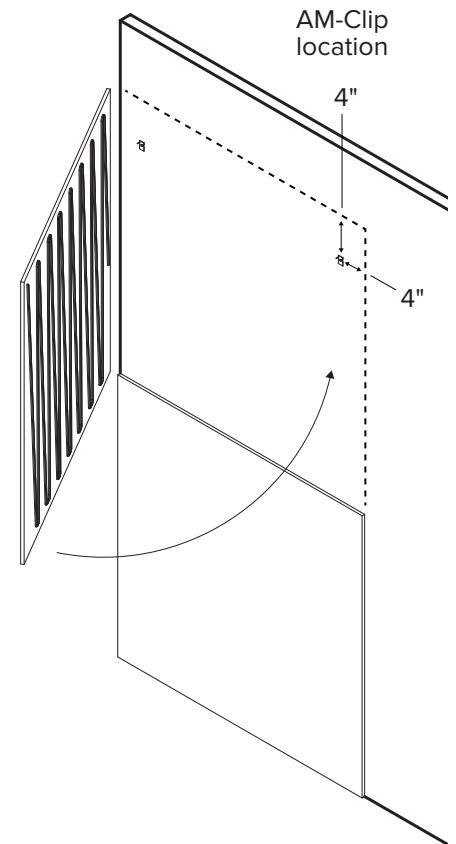

# aCapella SCORES - GamiLayer, Flute - Wall Panels

## AM-Clip with Adhesive - Wall Installation

3. Apply a 1/4" bead of heavy bodied water-based adhesive to the back of each Score panel in a zig zag pattern as shown below. Cover the entire wall panel, keeping adhesive 1/2" away from each edge.
4. Being careful not to touch the adhesive, lift the Score panels in place. Apply panel to the wall, pressing firmly on the front face of the panel to engage the adhesive and AM-Clips.
5. To ensure the Score panels are evenly secured, apply pressure with hands moving them from center to outer edge of each wall panel.
6. Use a straight edge and utility knife to cut Score panels to fit around odd angles, lights and other penetrations.

### HANDLING AND STORAGE

aCapella panels must be stored indoors in a dry, climate controlled environment at all times. Exposure to moisture, excessive heat or humidity can cause panels to warp and/or stain.

Panels should be stored in a flat, fully supported, horizontal position and NOT on edge. It is recommended that 2 people carry each panel. Panel should be carried on edge, being careful not to bend panel at any time. Clean white gloves are also recommended when handling aCapella panels.

### MOUNTING DETAILS

#### Step 3

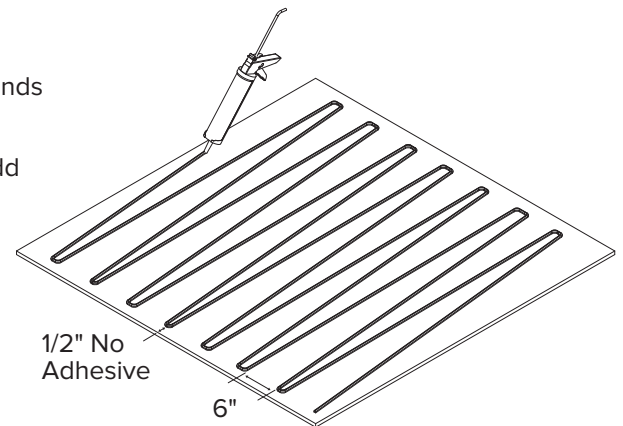

Ribbon Pattern or Zig Zag Pattern  
with Perimeter Bead on back of panel